



Introduction-How a Two Stroke Engine Works	1	Crankcase	12
Specifications	1	Crankshaft	12
Troubleshooting, Diagnosis & Remedies		Main Crankshaft Bearing	12
Questions to Ask Customers	3	Assembly of Crankcase, Crankshaft and Main Crankshaft Bearing	13
Look at the Air Filter First	3	Crankshaft Seals	13
Quick Check of Piston and Cylinder	3	Recoil Assembly	13
Start of in-Depth Testing	3	Blades	14
If the Engine Will Not Start	4	Belt cover	14
Carburetor	4	Cutting Arm	14
Air Leaks	7	Blade Flanges	14
Ignition system	7	Blade Drive Pulley	14
If there is no spark	7	Blade Shaft or Spindle	15
Lubrication	7	Blade Shaft Bearings	15
Cooling System	7		
Disassembly and Assembly Procedures			
Air Filter	8		
Starter Cover	8		
Filter fix foundation	8		
Carburetor	8		
Cylinder	8		
Piston Rings	9		
Piston	9		
Muffler	9		
Clutch	9		
Ignition Module	11		
Starter Pawls	11		
Flywheel	11		
Decompression Valve	12		

HOW A TWO STROKE ENGINE WORKS

The two-cycle engine is used almost exclusively in hand held gasoline power equipment. The CS saw is of typical design, yet incorporates unique features which maximize performance to meet the heavy demands of the construction industry.

The carburetor performs the same function as with other engines. It mixes the fuel with air in a fixed ratio to assure the most efficient combustion of the fuel. The fuel vapor travels through the crankcase on its way to the combustion chamber and provides a cooling effect as well as critical lubrication to the engine components. Oil is mixed with the gas to provide this lubrication.

1. The fuel vapor is drawn from the carburetor through the reed valve. Negative pressure created inside the crankcase is the drawing force that opens the reed valve. The negative pressure, or vacuum, is created in the crankcase by two actions: the upward movement of the piston, and the scooping action of the crankshaft counterweight.
2. At or near TDC (Top Dead Center), the ignition module provides the current (spark) to the spark plug. Starting combustion. The burning and expanding gases push the piston down, providing the power "stroke" needed to turn the crankshaft.
3. As the piston moves downward, the exhaust port is exposed by the descending piston, releasing the hot expanded gases (exhaust) out through the muffler.
4. As the downward movement of the piston continues, the intake port is exposed, allowing new fuel vapor to enter the combustion chamber. Positive pressure, created in the crankcase by the downward movement of the piston, forces

the vapor into the combustion chamber. Note that this positive pressure in the crankcase also closes the reed valve.

As the piston begins its upward motion, beginning the compression part of the cycle, the intake port is closed before the exhaust port. Because of this, some unspent fuel vapor is expelled through the exhaust port.

The cycle is now complete, and starts over again. Since complete engine cycle takes two "strokes" of the piston, this type of engine is known as "two stroke" or "two cycle".

A thorough understanding of the principles of two cycle engine operation is your key to servicing the saw. Review this service manual carefully, and keep it nearby when working on CS saw.

SPECIFICATION

Bore & Stroke	1.89" x 1.34" (48mm x 34mm)
Displacement	3.8 cu.in (61.5 cm3)
Compression Ratio	7.5:1
Compression Pressure	150psig (1035kPa)
Piston Ring Gap	0.088" - 0.10" (2.24mm - 2.54mm)
Spark Plug	NGK BPMR7A
Spark Plug Gap	0.025" (0.63mm)
Flywheel/Module Gap	0.012" - 0.016" (0.3mm - 0.4mm)
Fuel Capacity	0.7L
Fuel/Oil Mix Ratio	50:10
Clutch	3 Shoes Centrifugal
RPM Max H.P. Engine	8500
Blade Shaft RPM, No Load	5000
Starter Cord	35" x 0.157"

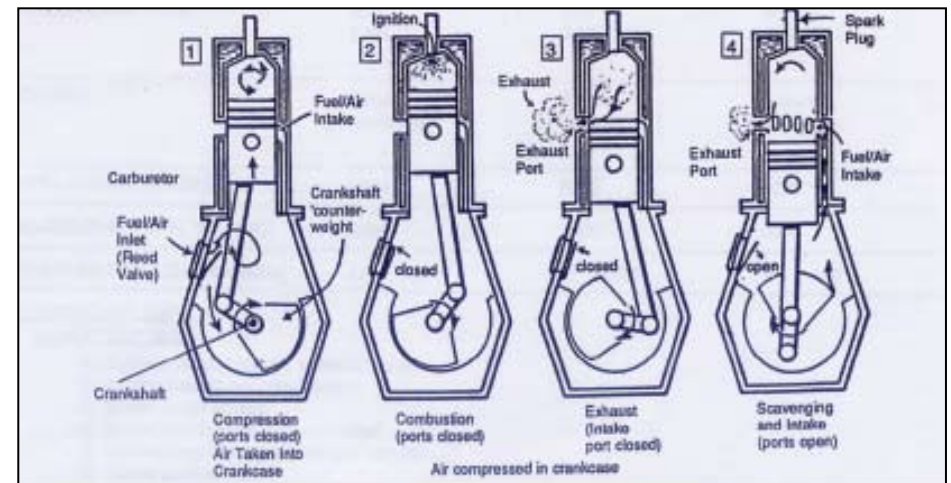

TROUBLESHOOTING, DIAGNOSTIC & REMEDIES

QUESTIONS TO ASK CUSTOMERS

Basic questions to ask customers when they bring a CS saw in for repair:

1. What did it sound like when it stopped?
2. Have you noticed the problem before?
3. How long has it been since you last operated it?
4. Is it hard to start?
5. When was it tuned up and serviced last?

Use a systematic approach. There are six systems involved in a CS saw. These are:

Filter System

Fuel System

Ignition System

Pressure System

Cooling System

Lubrication System

Complete disassembly and assembly instructions are included later in this book.

Always document everything you're told about the saw for reference on a repair tag or service order form. Review your notes on what the customer told you about the saw, but do not take his word as absolute proof. It is important to do your own diagnosis.

LOOK AT THE AIR FILTER FIRST

The first place to look is the air filter assembly. It is easy to sight contaminants that have leaked in through the air filter assembly. The inside of the rubber carburetor boot should be free from any dust. The cause for this is most often operator error-not reinstalling the air filter assembly correctly, or not cleaning and replacing filter elements often enough.



QUICK CHECK OF PISTON AND CYLINDER

Another quick way to detect engine problems without a major overhaul is to remove the muffler and look at the piston through the exhaust port for signs of damage. A bluish discoloration means the unit has overheated. Vertical scratches mean contaminants have gotten inside the engine. Either case means a major overhaul will be necessary to fix the saw.

START OF IN-DEPTH TESTING

Further in-depth testing will be necessary if inspection of the air filter system and piston doesn't reveal any probable causes for saw malfunction.

Add fresh fuel mix in the fuel tank, and make sure the fuel pick-up filter is situated in the bottom of the tank.

Make sure the carburetor mixture needles are at one turn open.

Pull the starter rope at least one dozen times to get a feel for the engine's compression.

CAUTION: It is permissible to start an engine without the cutting arm installed, but **DO NOT** start it with a threaded clutch driver to hold the clutch in place. Use a nut instead. There is a very real danger of the clutch driver coming loose and striking the operator.

IF THE ENGINE WILL NOT START

If the engine will not start, pull the spark plug. If it is wet with fuel, either the plug is faulty, the carburetor is flooding, the reed valve is broken or the electrical system is not producing a spark.

Use a test plug to test the electrical system. A standard spark plug is not recommended because it does not simulate the compressed environment that a “test” plug does and, consequently, does not require as much voltage to fire. A test plug will reveal problems that a standard plug would not.

CAUTION: Keep the test plug **AWAY** from the cylinder opening during testing so that it will not ignite fuel vapors escaping from the combustion chamber.

If the engine has spark and the spark plug is dry, the fuel system needs to be thoroughly examined.

Disconnect the fuel line from the carburetor and check it for cracks, pin holes or obstructions. Connect a pressure gauge to one end of the hose, pinch the other end shut, pump air into the hose and see if it holds pressure. Also inspect the fuel filter to see if it needs replacing.

If the fuel line is in satisfactory condition, the carburetor needs to be inspected.

CARBURETOR

The carburetor is designed so that it does not have to be removed in order to perform maintenance. However, should you desire to remove the carburetor for easier access to its components, it is a simple matter of taking out the screws on either side of the air intake passage.

This carburetor is specially designed for use on CS. While other

carburetors may fit, they are not governed to CS’s specifications and could cause dangerous overspeeding of the blade.

Remove the carburetor pump cover and check the fuel inlet screen for foreign material.

Whenever installing a carburetor diaphragm gasket kit, remember that on the meter side the gasket goes next to the casting, the diaphragm sets on top of it, and then the cover.

On the pump side, the diaphragm goes next to the casting, the gasket sets on top of it, then the cover.

Sticking Needles:

Attach a pressure gauge to the fuel inlet nozzle of the carburetor and pump pressure into the carburetor. When the metering diaphragm is depressed, pressure should fall on the gauge. If it does not, the carburetor inlet needle is stuck, causing fuel starvation. In this case, the carburetor would have to be disassembled and cleaned to solve the problem.

Test the reed valve for air tightness by holding it up to a light and seeing if any light is visible between the reed and reed case.

Disassemble the reed valve and inspect the reed case for damage. Look carefully for scratches, dents or abrasions on the surface area that meets with the reed. Check the reed to see that it is not bent or scratched.

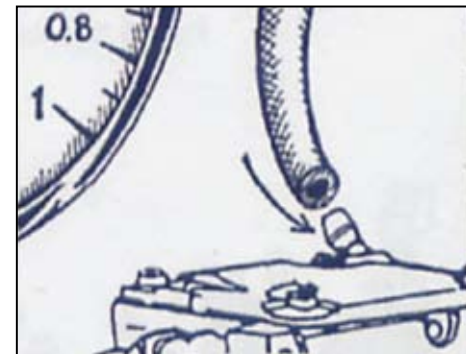

To clean the carburetor:

First scrub the outside thoroughly. Work on spread out sheets of paper for a low-dust working surface. Cleanliness is important. Use a cleaner specially suited for a carburetor, and a plastic bristled brush.

Remove the high speed needle and the low speed needle. Inspect them for damage, making sure they have not been bent from overtightening. Clean them thoroughly.

Remove the high speed and low speed Welsh Plugs. This can be done with a drill or punch. The Welsh Plugs are comprised of a screen, a clip, and a plug. Check the screen to see if any foreign material has been trapped by it, causing disruption of fuel flow.

A scratch in this area would cause the carburetor to flood and would have to be replaced.

Use a staking tool and small hammer to install the new Welsh Plugs. Apply lacquer paint to the outside of the Welsh Plugs to insure an airtight seal. Replace all three components of the Welsh Plug when rebuilding the carburetor.

If the throttle return spring is broken, the throttle plate has to be removed to access the spring. Scribe a mark on the throttle plate before it is removed to provide a reference point for reinstallation. The throttle plate appears to be round, but is actually oval. Consequently, it is very important to install it in the same position.

If the plate is put in upside down or backwards, it may stick in the throttle bore, resulting in an erratic idle. A screw in the middle of the throttle plate is all that holds it in place. Always use Loctite on the throttle plate and screw when installing.

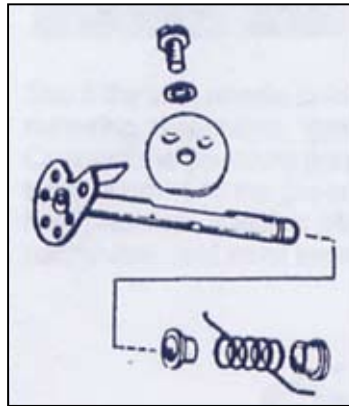

Cold, hard starting and/or erratic idle may also be caused by wear on the throttle and choke shafts. Check the chrome plating to see if it has been worn off from vibration. The worn shafts will allow dirt to work its way into the carburetor and cause damage to the power head.

Connect the fork to the inlet needle for the installation of the metering lever.



Use a straight edge to check its height. The lever should be flush with the floor of the metering chamber.

A high lever will cause flooding. A low lever will cause poor acceleration and poor idle.

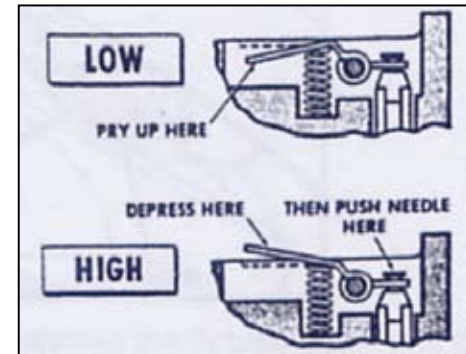

To correct these conditions, hold the inlet needle end of the lever in place and pry up or down on the other end of the lever until it is flush with the floor of the metering chamber.

The one-way venting valve is located in the gas cap. Only atmospheric pressure passes through this valve. An external vent is not necessary.

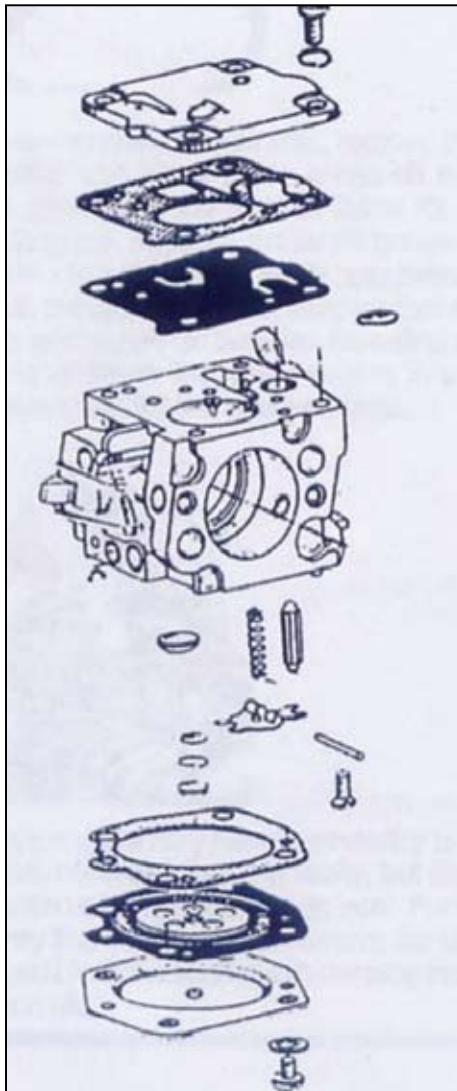

See if the inlet needle holds pressure before installing the metering diaphragm, gasket and cover back in place.

Connect the pressure gauge to the carburetor and apply a minimum of 10lbs. pressure. If the inlet needle does not hold pressure, it will not allow even flow of fuel through the carburetor, and must be replaced.

Place the gasket next to the casting, then connect the button on the underside of the diaphragm to the fork of the inlet lever. The carburetor is equipped with a governor that controls the maximum speed of the engine.

The governor is vibration activated. The governor is made up of a brass capsule, a calibrated spring, steel ball and seat.

JCB's governor is unique to the CS. Best suited for diamond blade cutting. When ordering a new governor, refer directly to the number inscribed directly on the governor that is being replaced

Setting the Carburetor:

Facing the adjusting hole, on its left side is a high speed screw. On its right side is a low speed screw. Before leaving the factory, the carburetor is basically set. If you would like to set the basic set again, please close the engine, check if the air filter is clean, tighten the H (high speed screw) and L (low speed screw) clockwise to the end carefully, and then rotate the H speed screw 1 1/2 turns, while L speed screw 2 1/4 turns(basic set). Run the engine for five minutes. If the high speed of engine is too high or too low, adjust T (idle speed screw) to make the rotation speed of engine be approximate to 2500 rpm.

Adjust the low speed screw first. While the engine is idling, rotate the low speed screw clockwise until the engine speeds up and becomes too lean. Note the position of the needle slot, then turn the screw out until the engine runs too rich. Again, note position of the needle slot, then turn the screw back in, half way between the two noted positions.

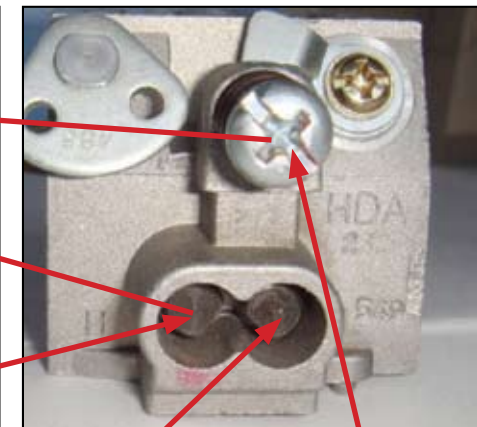

H (high speed screw)

L (low speed screw)

T (idle speed screw)

To adjust the high speed screw, start the engine and run it wide open. Lower the blade into a cut to put the engine under load. Apply enough pressure to stall the clutch for three to five seconds. Be careful, stalling the clutch for any longer than five seconds can cause it damage. If the engine stalls when the clutch is stalled, the mixture is too lean. Adjust the high speed screw 1/8 of a turn richer and try the stall test again. Repeat the test if necessary.

It will lead to the decline of the power, overheated and malfunction of the engine if the concentration of mixture which is set by H (high speed screw) is too low. The high speed screw is used to adjust the maximum power instead of maximum speed.

AIR LEAKS

An air leak is best detected when the engine is idling. The engine will run stable for three to five seconds, then speed up, slow down, then speed up again until it suddenly quits in a lean condition.

To test for air leaks, spray WD-40 around the cylinder base gaskets, the carburetor and manifold gaskets, and the driveside crankcase seal while the engine is idling in this lean condition. Watch for air bubbles, which would indicate an air leak.

If this method does not reveal the air leak, remove the carburetor and muffler and bland these areas off with the bland-off plates provided in the air leak tester kit. Leave the spark plug in place, attach a pressure gauge to the nipple fitting of the carburetor, and apply approximately 8 lbs. of pressure to the crankcase. Put soapy water around the gasket seals and watch for bubbles revealing a leak. You may have to immerse the entire engine in a vat of water or kerosene to detect the problem area.

The decompression valve may have a tendency to leak a little air.

This does not mean that it is faulty, but cleaning the decompression valve will improve its seal. For the air leak test, you may find it desirable to remove the decompression valve and block the socket with the plug provided in the air leak test kit.

IGNITION SYSTEM

Problem: Engine fails to start.

1. Check for spark using test plug.
2. Check ignition switch
3. Check all wires and connections.

IF THERE IS NO SPARK

If there is no spark, you will need a continuity tester, a test spark plug, and a high tension lead. The ignition module cannot be serviced. It has to be replaced if it is not working.

Disconnect the ignition switch and turn the engine over. The engine must be turned over at least 600 to 800 RPM to energize the system. If the test plug produces a spark, the ignition switch is faulty. Simply replace it.

If the switch is not the problem, disconnect the other end of the switch wire from the ignition module. Replace the starter housing and turn the engine over. If the test plug produces a spark this time, it means that the switch wire is damaged and needs to be replaced.

If the problem is still undetected, the next step is to test the flux levels (magnetic pulling power) of the flywheel magnets using a screwdriver. Experience will tell you what is adequate.

Check the gap between the flywheel and the ignition module. It

should be 0.012" to 0.018".

If the high tension lead passes a continuity and leakage test, it means the ignition module has to be replaced.

LUBRICATION

Pistons scored from top to bottom mean the engine was not getting adequate lubrication. When disassembled, the wrist pins will be blue in color, the main bearings will be very dry, the spark plug will be powdery white, and the inside of the muffler will be very dry.

COOLING SYSTEM

The cooling is comprised of three components: the fan housing, flywheel and cylinder fins. It is important for an operator to clean these parts regularly to prevent overheating.

DISASSEMBLY AND ASSEMBLY PROCEDURES

Always empty the gas tank before starting to disassemble the saw.

AIR FILTER

The filter system is made up of pre-filter sponge, paper filter, inner filter. Prior to disassembly, clean the exterior of any dust or dirt to avoid contaminates from entering the carburetor. Inspect the washer gasket and filter housing gasket for damage.

Rinse the pre-filter sponge in warm soap water. Before fitting, soak it in to the engine oil and squeeze out extra oil. Clean the inner filter by using gasoline.

To get to the cylinder and piston, the following must be removed in this order:

Cutting Arm (See page 18)

1. Starter Cover
2. Filter fix foundation
3. Carburetor



STARTER COVER

The starter cover is held in place with four screws, two in the bottom frame and two at the top.

FILTER FIX FOUNDATION:

The filter fix foundation is held in place by three screws.



CARBURETOR

The carburetor does not have to be removed to service it.

Loosen the two screws on either side of the carburetor throat. Disconnect the choke throttle linkage and the fuel line. Now the carburetor can be easily lifted out.



CYLINDER

Turn the crankshaft until the piston is in the lowest position. Then, loosen and remove the four hex head bolts that hold the cylinder to the crankcase. The cylinder should separate from the crankcase with minimal effort.

Inspect the base gasket to ensure there has been no leakage. This gasket should be replaced on reassembly of the saw.

Torque the four hex head bolts down to between 130 and 142 inch pounds. Be sure to use an "x" pattern when tightening these bolts to assure an even seal.

A ring compressor provides an easy way to compress the rings during installment of the cylinder, but if one is not available, it can be done by hand.



PISTON RINGS

Test for wear of the piston ring groove with a feeler's gauge. There should be no more than .010" space between the ring and groove.

The two piston rings can easily be popped out of the slots in the piston. When installing the rings, make sure that they are lined up with the pin in the piston ring's groove.

Check the ring end gap by removing the rings and placing them in the cylinder. Use the top of the piston to push the ring into the cylinder. Note that the ring should not be able to fall into the cylinder freely; some pressure should be necessary. It should be a snug fit. Measure the end gap with a feeler's gauge at the bottom and top of the cylinder. The end gap should not exceed 0.100". If the end gap does exceed 0.100", the cylinder should be replaced.

Look for blue discoloration of the wrist pin, piston bearings and connecting rod. This discoloration is a sign of overheating and may mean the bearings and piston are ruined. Inspect the piston bearings, making sure that there is no play between the connecting rod, bearings and wrist pin, only smooth rotation.

PISTON

Remove the wrist pin clips with a pair of needle nose pliers. These clips should not be reused and new ones should be installed on reassembly.

The wrist pin is slip fit. It will slide out of the sleeve with easy pressure. With the wrist pin removed, the piston will separate from the connecting rod. Note that the closed end of the wrist pin goes on the same side as the exhaust port. The piston is marked with an "➔" on the top. The arrow always goes toward the exhaust port in reassembly.

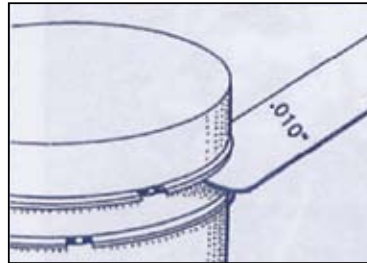

MUFFLER

The muffler is removed by taking out three bolts. Loctite should be applied to the muffler bolts upon assembly. Components of the muffler are the rear body, cover, three bolts, one spacer, a bracket.



CLUTCH

Use a special tool to hold the flywheel. This will hold the clutch and crankshaft in position for removal of the right hand threaded clutch nut.





Pull the clutch off the crankshaft.

To remove the shoes and spring, insert a large screwdriver in one of the openings between a shoe and the hub and pry outward. When the shoe is out far enough for the spring to clear the hub arm, pry it out with a smaller screwdriver. The whole unit will come apart easily now.

To reassemble, install the driver and two shoes easily, and roll the spring into its proper location, then squeeze the third shoe into place.

Inspect the clutch springs, driver and shoes for wear or damage. The back washer protects the seals from the clutch drum rubbing on it. The drum bearing is pressed into place.

The clutch may have three shoes. It is available as a replacement assembly.



Install the clutch in this sequence:

First, the washer, clutch drum slip the clutch on the crankshaft.

Second, follow it with the locking nut and tighten it down, torquing it from 228 to 252 inch pounds. The locking nut should not be used if it can be screwed on completely without a wrench

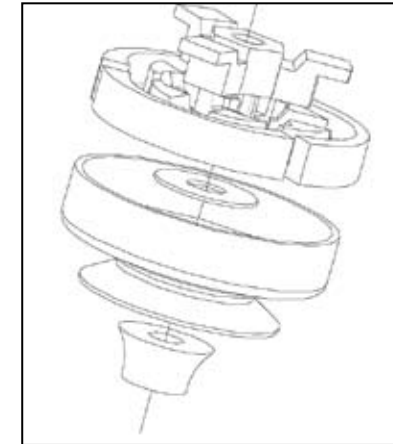

IGNITION MODULE

Remove the ground lead from the ignition module and inspect it for shorts, cuts or breaks. Check the high tension lead and make sure there are no cuts or short circuits in it.

Take out the two screws and the ignition module is now free.

When reinstalling the ignition module, use a feeler gauge to set the gap between the flywheel and ignition module an .012" to .016". Rotate the flywheel so that the magnet is near the ignition module during this setting. Tighten the ignition module securely (use Loctite) when the proper gap is established .The gap should be consistent at all points of the ignition module that come close to the flywheel. Connect the ground wire to the ignition module.



STARTER PAWLS

The starter pawl consists of the hold down bolt, the pawl, washer and a spring. All these parts should be checked for wear. The pawls should be lubricated with a DRY graphite or molybdenum grease. DO NOT use wheel bearing grease.

Once the pawl is removed, the right hand thread nut on the flywheel may be taken off. There is a washer under the nut and the steel hub should be checked for cracks or signs of damage.



FLYWHEEL

A special flywheel and crankcase puller is used to remove the flywheel. With a piston stop in place, put the puller over the crankshaft, thread the screws into the pawl bolt holes, and turn the jack screw until the flywheel pops off. A half-inch wrench is used to turn the jack screw in. Use a pair of side cutters to remove the flywheel key. To reassemble the flywheel, install the flywheel key, and put the flywheel on the crankshaft, followed by the washer and flywheel nut.

Insert the piston stop to hold the crankshaft in place. Tighten the flywheel nut with a torque wrench to 240 to 300 inch pounds. Use Loctite on the nut.

Note that a broken fin will throw the balance of the flywheel off and hamper the smooth cycle of the engine.





DECOMPRESSION VALVE

To remove the decompression valve, use a wrench to unscrew the valve from the cylinder wall.

Decompression valves collect carbon over a period of time, so it is a good idea to clean it regularly. A dirty decompression valve may not close completely, causing the engine to lose compression/power.



CRANKCASE

Remove the fuel line and take out the connecting nipple. There is a screw under the nipple that must be removed to separate the crankcase halves. There are also other bolts in this area.

When these bolts have been removed, pull the crankcase evenly by your hand, it should pop the crankcase halves off evenly. Do not use a screwdriver to pry the crankcase apart.



CRANKSHAFT

To remove the crankshaft from the case half, using a press, with proper tools, seat the unit so that the shaft can slide out when pressure is applied. In the field, a large socket works well when used with a rawhide or plastic mallet. Ensure the crankshaft out of the crankcase half not drop on the floor.

MAIN CRANKSHAFT BEARING

Inspect the bearings while they are on the shaft by standing the shaft on end and rotating the bearings while applying downward pressure with your hand. A good bearing will rotate smoothly. A bad bearing will feel slightly grainy during rotation.

Also look for signs of overheating blue discoloration of the bearings and connecting rod.

Inspect the bearings for “play”. A slight rocking play of the connecting rod is OK, but if the connecting rod plays up and down, the crankshaft needs to be replaced.

If the main bearings have to be removed from the crankcase, using a press, with proper tools, the bearing can slide out easy.



ASSEMBLY OF CRANKCASE, CRANKSHAFT, AND MAIN CRANKSHAFT BEARING:

Support the frame well, with a suitable punch, the bearings can be press into the frame.

When installing new bearings, it is important to apply pressure **ONLY** to the outer race.

Replace the crankcase gaskets and then line the two dowel pins up and slip the two halves together. Use Loctite on all the crankcase screws. Rotate the crankshaft to check for binding as you continue to tighten the screws. The crankshaft should be able to spin freely. If it does not, loosen the screws and tap the crankcase halves with a rawhide mallet until they align precisely enough to allow free spinning of the crankshaft. Tighten down the screws evenly from 40 to 53 inch pounds.



CRANKSHAFT SEALS

Use a screwdriver to pry the seal apart.

In much the same fashion, slide the new seal over the steps on the crankshaft, being careful not to damage the seal.



RECOIL ASSEMBLY

Relieve pretension on the rewind spring by holding the pulley and unwrapping the rope from the pulley, or simply cut the rope at the handle. It is suggested that the rope always be replaced when servicing the starter assembly.

Loosen the screw in the center of the pulley and carefully slip the pulley off the starter so as not to cause the rewind spring to unravel. Do not lubricate the rewind spring with any kind of lubricant. Inspect all components for wear or damage, including the starter pawls and spring on the flywheel. Clean all parts thoroughly and replace any worn parts. Lubricate starter pawls with a dry graphite or molybdenum grease. Do not use wheel bearing grease.

Tie a knot in the end of the rope and thread the other end through the hole in the pulley and out the hole in the recoil housing. Pull it all the way through and push the knot down into the hole, making sure that it does not protrude.



Wind the 2/3 rope around the pulley anticlockwise and thread the end of rope through the side hole on the pulley. After rotate the pulley three turns clockwise, return the rope to the groove of the pulley. At the force of recoil spring, the 1/3 rope will completely wind around the pulley.



Install the pulley onto the starter. Make sure that it is engaged with the rewind spring. Tighten the pulley screw down, making sure the flat washer is positioned properly on the shaft.



BLADES

Removing a Blade: Loosen the blade flange bolt with a wrench. To prevent the blade shaft from turning, insert a pin into the small hole in the front of the belt guard far enough to enter the hole in the inside flange. The flange hole and belt guard hole need to be lined up.



BELT COVER

The belt cover can be removed. Remove the two bolts on the side. Now relieve tension on the belt by turning the belt tension screw.



CUTTING ARM

The cutting arm can be removed as a unit for access to the engine and other components. Remove the two nuts that hold the cutting arm frame to the engine and the clutch cover in place. Remove the clutch cover and tilt the cutting arm at a sharp angle away from the engine for clearance of the cutting arm frame from around the clutch.



BLADE FLANGES

The outer flange slips off easily. The inner flange should come off with a firm pull. Inspect the flanges for scoring or edge wear. The flat surfaces that come in contact with blades should be smooth and free from wear. The keyways and pilots, or interior surfaces of the holes, should also be free of wear.

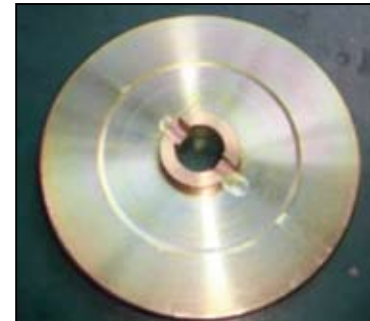

BLADE DRIVE PULLEY

Put the pin back into the locking hole so a wrench can be used to remove the pulley nut. Rotate the pulley while prying it with a screwdriver until it comes off the shaft.

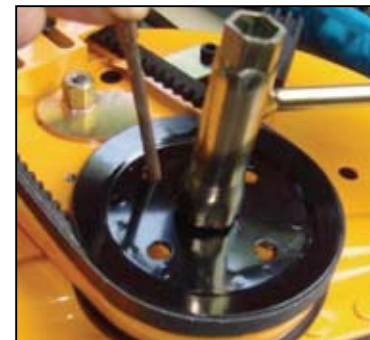

BLADE SHAFT

Using a press, with proper tools, seat the unit so that the shaft can slide out when pressure is applied. In the field, a large socket works well when used with a rawhide or plastic mallet.



**IF YOU HAVE ANY FURTHER QUESTIONS,
PLEASE CONTACT YOUR DEALER OR
CALL +44 (0)1332 226699 FOR TECHNICAL
QUESTIONS.**

BLADE SHAFT BEARINGS

In much the same fashion, support the frame so that, with a suitable punch, the bearings can be tapped out. Do not try to tap them out from the same side; come in from the opposite side with the punch. Bearings are never reinstalled. The only time they are removed is when they are to be replaced with a new set.

There are two spacers one is between the bearings, the other is between the bearing and the pulley.

When installing new bearings, it is important to apply pressure **ONLY** to the outer race. Press the bearing onto the shaft first, then press the shaft/bearing into the frame.

Finally, press the other bearing into the frame, using the shaft as a guide.



Edge Tools & Equipment Ltd, Unit 9, Victoria Centre, Victoria Way, Pride Park, Derby, DE24 8AN.
Tel: +44(0)1332 3210211 • Fax: +44(0)1332 210211 • Email: sales@edgediamond.com • www.jcbdiamond.com

JCB's Cut Off Saw is manufactured under license by Edge Tools & Equipment Ltd.